

**(12) STANDARD PATENT**  
**(19) AUSTRALIAN PATENT OFFICE**

(11) Application No. **AU 2011227531 B2**

(54) Title  
**Split-cycle air-hybrid engine with compressor deactivation**

(51) International Patent Classification(s)  
**F02B 25/00** (2006.01)                      **F02B 41/06** (2006.01)  
**F02B 33/22** (2006.01)

(21) Application No: **2011227531**                      (22) Date of Filing: **2011.03.14**

(87) WIPO No: **WO11/115870**

(30) Priority Data

| (31) Number       | (32) Date         | (33) Country |
|-------------------|-------------------|--------------|
| <b>61/363,825</b> | <b>2010.07.13</b> | <b>US</b>    |
| <b>61/365,343</b> | <b>2010.07.18</b> | <b>US</b>    |
| <b>61/313,831</b> | <b>2010.03.15</b> | <b>US</b>    |

(43) Publication Date: **2011.09.22**

(44) Accepted Journal Date: **2012.11.01**

(71) Applicant(s)  
**Scuderi Group, LLC**

(72) Inventor(s)  
**Meldolesi, Riccardo;Badain, Nicholas;Gilbert, Ian**

(74) Agent / Attorney  
**Davies Collison Cave, Level 14 255 Elizabeth Street, Sydney, NSW, 2000**

(56) Related Art  
**US 4630447 A**  
**US 20070017203 A1**  
**US 7628126 B2**  
**US 20030014971 A1**  
**US 20040255882 A1**  
**US 20070157894 A1**  
**US 20080105225 A1**  
**US 20080202454 A1**  
**US 20090038596 A1**  
**US 20090038598 A1**  
**US 20090301086 A1**  
**US 20040139934 A1**  
**US 20060124085 A1**  
**US 4359979 A**  
**US 20090266347 A1**

(19) World Intellectual Property Organization  
International Bureau



(10) International Publication Number  
**WO 2011/115870 A1**

(43) International Publication Date  
22 September 2011 (22.09.2011)

(51) International Patent Classification:  
*F02B 25/00* (2006.01) *F02B 41/06* (2006.01)  
*F02B 33/22* (2006.01)

**BADAIN, Nicholas**; 37 Rosslyn Road, Shoreham-By-Sea, West Sussex BN43 6WL (GB). **GILBERT, Ian**; 67 Beach Green, Shoreham-By-Sea, West Sussex BN43 5YE (GB).

(21) International Application Number:  
PCT/US2011/028281

(74) Agents: **FILDES, Christoher, J.** et al.; Fildes & Outland, P.C., 20916 Mack Avenue, Suite 2, Grosse Pointe Woods, MI 48236 (US).

(22) International Filing Date:  
14 March 2011 (14.03.2011)

(25) Filing Language: English

(81) Designated States (unless otherwise indicated, for every kind of national protection available): AE, AG, AL, AM, AO, AT, AU, AZ, BA, BB, BG, BH, BR, BW, BY, BZ, CA, CH, CL, CN, CO, CR, CU, CZ, DE, DK, DM, DO, DZ, EC, EE, EG, ES, FI, GB, GD, GE, GH, GM, GT, HN, HR, HU, ID, IL, IN, IS, JP, KE, KG, KM, KN, KP, KR, KZ, LA, LC, LK, LR, LS, LT, LU, LY, MA, MD, ME, MG, MK, MN, MW, MX, MY, MZ, NA, NG, NI, NO, NZ, OM, PE, PG, PH, PL, PT, RO, RS, RU, SC, SD, SE, SG, SK, SL, SM, ST, SV, SY, TH, TJ, TM, TN, TR, TT, TZ, UA, UG, US, UZ, VC, VN, ZA, ZM, ZW.

(26) Publication Language: English

(30) Priority Data:  
61/313,831 15 March 2010 (15.03.2010) US  
61/363,825 13 July 2010 (13.07.2010) US  
61/365,343 18 July 2010 (18.07.2010) US

(71) Applicant (for all designated States except US): **SCUD-ERI GROUP, LLC** [US/US]; 1111 Elm Street, Suite 33, West Springfield, MA 01089 (US).

(72) Inventors: **MELDOLESI, Riccardo**; 55 New Road, Shoreham-By-Sea, West Sussex BN43 6RB (GB).

(84) Designated States (unless otherwise indicated, for every kind of regional protection available): ARIPO (BW, GH,

[Continued on next page]

(54) Title: SPLIT-CYCLE AIR-HYBRID ENGINE WITH COMPRESSOR DEACTIVATION

FIG. 1

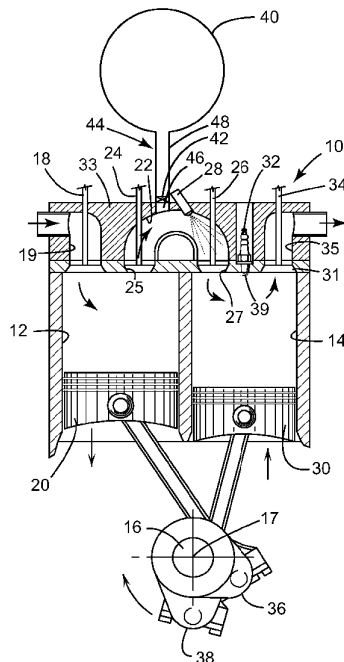

(57) Abstract: A split-cycle air-hybrid engine includes a rotatable crankshaft. A compression piston is slidably received within a compression cylinder and operatively connected to the crankshaft. An intake valve selectively controls air flow into the compression cylinder. An expansion piston is slidably received within an expansion cylinder and operatively connected to the crankshaft. A crossover passage interconnects the compression and expansion cylinders. The crossover passage includes a crossover compression (XovrC) valve and a crossover expansion (XovrE) valve therein. An air reservoir is operatively connected to the crossover passage. In an Air Expander (AE) mode and an Air Expander and Firing (AEF) mode of the engine, the XovrC valve is kept closed during an entire rotation of the crankshaft, and the intake valve is kept open for at least 240 CA degrees of the same rotation of the crankshaft.

WO 2011/115870 A1



GM, KE, LR, LS, MW, MZ, NA, SD, SL, SZ, TZ, UG,  
ZM, ZW), Eurasian (AM, AZ, BY, KG, KZ, MD, RU, TJ,  
TM), European (AL, AT, BE, BG, CH, CY, CZ, DE, DK,  
EE, ES, FI, FR, GB, GR, HR, HU, IE, IS, IT, LT, LU,  
LV, MC, MK, MT, NL, NO, PL, PT, RO, RS, SE, SI, SK,

SM, TR), OAPI (BF, BJ, CF, CG, CI, CM, GA, GN, GQ,  
GW, ML, MR, NE, SN, TD, TG).

**Published:**

— *with international search report (Art. 21(3))*

**SPLIT-CYCLE AIR-HYBRID ENGINE WITH COMPRESSOR DEACTIVATION****TECHNICAL FIELD**

This invention relates to split-cycle engines and, more particularly, to such an engine incorporating an air-  
5 hybrid system.

**BACKGROUND OF THE INVENTION**

For purposes of clarity, the term "conventional  
10 engine" as used in the present application refers to an internal combustion engine wherein all four strokes of the well-known Otto cycle (i.e., the intake (or inlet), compression, expansion (or power) and exhaust strokes) are contained in each piston/cylinder combination of the engine.  
15 Each stroke requires one half revolution of the crankshaft (180 degrees crank angle (CA)), and two full revolutions of the crankshaft (720 degrees CA) are required to complete the entire Otto cycle in each cylinder of a conventional engine.

Also, for purposes of clarity, the following  
20 definition is offered for the term "split-cycle engine" as may be applied to engines disclosed in the prior art and as referred to in the present application.

A split-cycle engine as referred to herein comprises:

25 a crankshaft rotatable about a crankshaft axis;  
a compression piston slidably received within a compression cylinder and operatively connected to the crankshaft such that the compression piston reciprocates through an intake stroke and a compression stroke during a  
30 single rotation of the crankshaft;

an expansion (power) piston slidably received within an expansion cylinder and operatively connected to the crankshaft such that the expansion piston reciprocates through an expansion stroke and an exhaust stroke during a single rotation of the crankshaft; and

a crossover passage (port) interconnecting the compression and expansion cylinders, the crossover passage including at least a crossover expansion (XovrE) valve disposed therein, but more preferably including a crossover compression (XovrC) valve and a crossover expansion (XovrE) valve defining a pressure chamber therebetween.

United States Patent No. 6,543,225 granted April 8, 2003 to Scuderi and United States Patent No. 6,952,923 granted October 11, 2005 to Branyon et al., both of which are incorporated herein by reference, contain an extensive discussion of split-cycle and similar-type engines. In addition, these patents disclose details of prior versions of an engine of which the present disclosure details further developments.

Split-cycle air-hybrid engines combine a split-cycle engine with an air reservoir and various controls. This combination enables a split-cycle air-hybrid engine to store energy in the form of compressed air in the air reservoir. The compressed air in the air reservoir is later used in the expansion cylinder to power the crankshaft.

A split-cycle air-hybrid engine as referred to herein comprises:

a crankshaft rotatable about a crankshaft axis;  
a compression piston slidably received within a compression cylinder and operatively connected to the crankshaft such that the compression piston reciprocates through an intake stroke and a compression stroke during a single rotation of the crankshaft;

an expansion (power) piston slidably received within an expansion cylinder and operatively connected to the crankshaft such that the expansion piston reciprocates through an expansion stroke and an exhaust stroke during a  
5 single rotation of the crankshaft;

a crossover passage (port) interconnecting the compression and expansion cylinders, the crossover passage including at least a crossover expansion (XovrE) valve disposed therein, but more preferably including a crossover  
10 compression (XovrC) valve and a crossover expansion (XovrE) valve defining a pressure chamber therebetween; and

an air reservoir operatively connected to the crossover passage and selectively operable to store compressed air from the compression cylinder and to deliver  
15 compressed air to the expansion cylinder.

United States Patent No. 7,353,786 granted April 8, 2008 to Scuderi et al., which is incorporated herein by reference, contains an extensive discussion of split-cycle air-hybrid and similar-type engines. In addition, this  
20 patent discloses details of prior hybrid systems of which the present disclosure details further developments.

A split-cycle air-hybrid engine can be run in a normal operating or firing (NF) mode (also commonly called the Engine Firing (EF) mode) and four basic air-hybrid  
25 modes. In the EF mode, the engine functions as a non-air hybrid split-cycle engine, operating without the use of its air reservoir. In the EF mode, a tank valve operatively connecting the crossover passage to the air reservoir remains closed to isolate the air reservoir from the basic  
30 split-cycle engine.

The split-cycle air-hybrid engine operates with the use of its air reservoir in four hybrid modes. The four hybrid modes are:

- 1) Air Expander (AE) mode, which includes using compressed air energy from the air reservoir without combustion;
- 2) Air Compressor (AC) mode, which includes storing compressed air energy into the air reservoir without combustion;
- 3) Air Expander and Firing (AEF) mode, which includes using compressed air energy from the air reservoir with combustion; and
- 4) Firing and Charging (FC) mode, which includes storing compressed air energy into the air reservoir with combustion.

However, further optimization of these modes, EF, AE, AC, AEF and FC, is desirable to enhance efficiency and reduce emissions.

#### SUMMARY OF THE INVENTION

The present invention provides a split-cycle air-hybrid engine in which the use of the Air Expander (AE) mode and the Air Expander and Firing (AEF) mode are optimized for potentially any vehicle in any drive cycle for improved efficiency.

More particularly, an exemplary embodiment of a split-cycle air-hybrid engine in accordance with the present invention includes a crankshaft rotatable about a crankshaft axis. A compression piston is slidably received within a compression cylinder and operatively connected to the crankshaft such that the compression piston reciprocates through an intake stroke and a compression stroke during a single rotation of the crankshaft. An intake valve selectively controls air flow into the compression cylinder. An expansion piston is slidably received within an expansion

cylinder and operatively connected to the crankshaft such that the expansion piston reciprocates through an expansion stroke and an exhaust stroke during a single rotation of the crankshaft. A crossover passage interconnects the compression and expansion cylinders. The crossover passage includes a crossover compression (XovrC) valve and a crossover expansion (XovrE) valve defining a pressure chamber therebetween. An air reservoir is operatively connected to the crossover passage and selectively operable to store compressed air from the compression cylinder and to deliver compressed air to the expansion cylinder. An air reservoir valve selectively controls air flow into and out of the air reservoir. The engine is operable in an Air Expander (AE) mode and an Air Expander and Firing (AEF) mode. In the AE and AEF modes, the XovrC valve is kept closed for an entire rotation of the crankshaft, and the intake valve is kept open for at least 240 CA degrees of the same rotation of the crankshaft.

A method of operating a split-cycle air-hybrid engine is also disclosed. The split-cycle air-hybrid engine includes a crankshaft rotatable about a crankshaft axis. A compression piston is slidably received within a compression cylinder and operatively connected to the crankshaft such that the compression piston reciprocates through an intake stroke and a compression stroke during a single rotation of the crankshaft. An intake valve selectively controls air flow into the compression cylinder. An expansion piston is slidably received within an expansion cylinder and operatively connected to the crankshaft such that the expansion piston reciprocates through an expansion stroke and an exhaust stroke during a single rotation of the crankshaft. A crossover passage interconnects the compression and expansion cylinders. The crossover passage



includes a crossover compression (XovrC) valve and a crossover expansion (XovrE) valve defining a pressure chamber therebetween. An air reservoir is operatively connected to the crossover passage and selectively operable  
5 to store compressed air from the compression cylinder and to deliver compressed air to the expansion cylinder. An air reservoir valve selectively controls air flow into and out of the air reservoir. The engine is operable in an Air Expander (AE) mode and an Air Expander and Firing (AEF)  
10 mode. The method in accordance with the present invention includes the following steps: keeping the XovrC valve closed for an entire rotation of the crankshaft; and keeping the intake valve open for at least 240 CA degrees of the same rotation of the crankshaft, whereby the compression  
15 cylinder is deactivated to reduce pumping work performed by the compression piston on intake air.

These and other features and advantages of the invention will be more fully understood from the following detailed description of the invention taken together with the  
20 accompanying drawings.

#### BRIEF DESCRIPTION OF THE DRAWINGS

In the drawings:

25 FIG. 1 is a lateral sectional view of an exemplary split-cycle air-hybrid engine in accordance with the present invention; and

FIG. 2 is a graphical illustration of pumping load (in terms of negative IMEP) versus engine speed in accordance  
30 with the present invention.

**DETAILED DESCRIPTION OF THE INVENTION**

The following glossary of acronyms and definitions of terms used herein is provided for reference.

5 In General

Unless otherwise specified, all valve opening and closing timings are measured in crank angle degrees after top dead center of the expansion piston (ATDCe).

10 Unless otherwise specified, all valve durations are in crank angle degrees (CA).

Air tank (or air storage tank): Storage tank for compressed air.

ATDCc: After top dead center of the compression piston.

ATDCe: After top dead center of the expansion piston.

15 Bar: Unit of pressure,  $1 \text{ bar} = 10^5 \text{ N/m}^2$

BMEP: Brake mean effective pressure. The term "Brake" refers to the output as delivered to the crankshaft (or output shaft), after friction losses (FMEP) are accounted for. Brake Mean Effective Pressure (BMEP) is the engine's  
20 brake torque output expressed in terms of a mean effective pressure (MEP) value. BMEP is equal to the brake torque divided by engine displacement. This is the performance parameter taken after the losses due to friction. Accordingly,  $\text{BMEP} = \text{IMEP} - \text{friction}$ . Friction, in this case is  
25 usually also expressed in terms of an MEP value known as Frictional Mean Effective Pressure (or FMEP).

Compressor: The compression cylinder and its associated compression piston of a split-cycle engine.

30 Expander: The expansion cylinder and its associated expansion piston of a split-cycle engine.

FMEP: Frictional Mean Effective Pressure.

IMEP: Indicated Mean Effective Pressure. The term "Indicated" refers to the output as delivered to the top of the piston, before friction losses (FMEP) are accounted for.

Inlet (or intake): Inlet valve. Also commonly referred to  
5 as the intake valve.

Inlet air (or intake air): Air drawn into the compression cylinder on an intake (or inlet) stroke.

Inlet valve (or intake valve): Valve controlling intake of gas into the compressor cylinder.

10 Pumping work (or pumping loss): For purposes herein, pumping work (often expressed as negative IMEP) relates to that part of engine power which is expended on the induction of the fuel and air charge into the engine and the expulsion of combustion gases.

15 Residual Compression Ratio during compression cylinder deactivation: The ratio (a/b) of (a) the trapped volume in the compression cylinder at the position just when the intake valve closes to (b) the trapped volume in the compression cylinder just as the compression piston reaches  
20 its top dead center position (i.e., the clearance volume).

RPM: Revolutions Per Minute.

Tank valve: Valve connecting the Xovr passage with the compressed air storage tank.

VVA: Variable valve actuation. A mechanism or method  
25 operable to alter the shape or timing of a valve's lift profile.

Xovr (or Xover) valve, passage or port: The crossover valves, passages, and/or ports which connect the compression and expansion cylinders through which gas flows from  
30 compression to expansion cylinder.

XovrC (or XoverC) valves: Valves at the compressor end of the Xovr passage.

XovrC-clsd-Int-clsd: XovrC valve fully closed and Intake valve fully closed.

XovrC-clsd-Int-open: XovrC valve fully closed and Intake valve fully open.

5 XovrC-clsd-Int-std: XovrC valve fully closed and Intake valve having standard timing.

XovrC-open-Int-clsd: XovrC valve fully open and Intake valve fully closed.

10 XovrC-std-Int-std: XovrC valve having standard timing and Intake valve having standard timing.

Referring to FIG. 1, an exemplary split-cycle air-hybrid engine is shown generally by numeral 10. The split-cycle air-hybrid engine 10 replaces two adjacent cylinders of a conventional engine with a combination of one  
15 compression cylinder 12 and one expansion cylinder 14. A cylinder head 33 is typically disposed over an open end of the expansion and compression cylinders 12, 14 to cover and seal the cylinders.

The four strokes of the Otto cycle are "split"  
20 over the two cylinders 12 and 14 such that the compression cylinder 12, together with its associated compression piston 20, perform the intake and compression strokes, and the expansion cylinder 14, together with its associated expansion piston 30, perform the expansion and exhaust  
25 strokes. The Otto cycle is therefore completed in these two cylinders 12, 14 once per crankshaft 16 revolution (360 degrees CA) about crankshaft axis 17.

During the intake stroke, intake air is drawn into the compression cylinder 12 through an intake port 19  
30 disposed in the cylinder head 33. An inwardly opening (opening inwardly into the cylinder and toward the piston) poppet intake valve 18 controls fluid communication between the intake port 19 and the compression cylinder 12.

During the compression stroke, the compression piston 20 pressurizes the air charge and drives the air charge into the crossover passage (or port) 22, which is typically disposed in the cylinder head 33. This means that  
5 the compression cylinder 12 and compression piston 20 are a source of high-pressure gas to the crossover passage 22, which acts as the intake passage for the expansion cylinder 14. In some embodiments, two or more crossover passages 22 interconnect the compression cylinder 12 and the expansion  
10 cylinder 14.

The geometric (or volumetric) compression ratio of the compression cylinder 12 of split-cycle engine 10 (and for split-cycle engines in general) is herein commonly referred to as the "compression ratio" of the split-cycle  
15 engine. The geometric (or volumetric) compression ratio of the expansion cylinder 14 of split-cycle engine 10 (and for split-cycle engines in general) is herein commonly referred to as the "expansion ratio" of the split-cycle engine. The geometric compression ratio of a cylinder is well known in  
20 the art as the ratio of the enclosed (or trapped) volume in the cylinder (including all recesses) when a piston reciprocating therein is at its bottom dead center (BDC) position to the enclosed volume (i.e., clearance volume) in the cylinder when said piston is at its top dead center  
25 (TDC) position. Specifically for split-cycle engines as defined herein, the compression ratio of a compression cylinder is determined when the XovrC valve is closed. Also specifically for split-cycle engines as defined herein, the expansion ratio of an expansion cylinder is determined when  
30 the XovrE valve is closed.

Due to very high compression ratios (e.g., 20 to 1, 30 to 1, 40 to 1, or greater) within the compression cylinder 12, an outwardly opening (opening outwardly away

from the cylinder) poppet crossover compression (XovrC) valve 24 at the crossover passage inlet 25 is used to control flow from the compression cylinder 12 into the crossover passage 22. Due to very high expansion ratios (e.g., 20 to 1, 30 to 1, 40 to 1, or greater) within the expansion cylinder 14, an outwardly opening poppet crossover expansion (XovrE) valve 26 at the outlet 27 of the crossover passage 22 controls flow from the crossover passage 22 into the expansion cylinder 14. The actuation rates and phasing of the XovrC and XovrE valves 24, 26 are timed to maintain pressure in the crossover passage 22 at a high minimum pressure (typically 20 bar or higher at full load) during all four strokes of the Otto cycle.

At least one fuel injector 28 injects fuel into the pressurized air at the exit end of the crossover passage 22 in correspondence with the XovrE valve 26 opening, which occurs shortly before expansion piston 30 reaches its top dead center position. The air/fuel charge enters the expansion cylinder 14 when expansion piston 30 is close to its top dead center position. As piston 30 begins its descent from its top dead center position, and while the XovrE valve 26 is still open, spark plug 32, which includes a spark plug tip 39 that protrudes into cylinder 14, is fired to initiate combustion in the region around the spark plug tip 39. Combustion can be initiated while the expansion piston is between 1 and 30 degrees CA past its top dead center (TDC) position. More preferably, combustion can be initiated while the expansion piston is between 5 and 25 degrees CA past its top dead center (TDC) position. Most preferably, combustion can be initiated while the expansion piston is between 10 and 20 degrees CA past its top dead center (TDC) position. Additionally, combustion may be initiated through other ignition devices and/or methods,

such as with glow plugs, microwave ignition devices or through compression ignition methods.

During the exhaust stroke, exhaust gases are pumped out of the expansion cylinder 14 through exhaust port 5 35 disposed in cylinder head 33. An inwardly opening poppet exhaust valve 34, disposed in the inlet 31 of the exhaust port 35, controls fluid communication between the expansion cylinder 14 and the exhaust port 35. The exhaust valve 34 and the exhaust port 35 are separate from the crossover 10 passage 22. That is, exhaust valve 34 and the exhaust port 35 do not make contact with, or are not disposed in, the crossover passage 22.

With the split-cycle engine concept, the geometric engine parameters (i.e., bore, stroke, connecting rod 15 length, volumetric compression ratio, etc.) of the compression 12 and expansion 14 cylinders are generally independent from one another. For example, the crank throws 36, 38 for the compression cylinder 12 and expansion cylinder 14, respectively, may have different radii and may 20 be phased apart from one another such that top dead center (TDC) of the expansion piston 30 occurs prior to TDC of the compression piston 20. This independence enables the split-cycle engine 10 to potentially achieve higher efficiency levels and greater torques than typical four-stroke engines.

25 The geometric independence of engine parameters in the split-cycle engine 10 is also one of the main reasons why pressure can be maintained in the crossover passage 22 as discussed earlier. Specifically, the expansion piston 30 reaches its top dead center position prior to the 30 compression piston reaching its top dead center position by a discreet phase angle (typically between 10 and 30 crank angle degrees). This phase angle, together with proper timing of the XovrC valve 24 and the XovrE valve 26, enables

the split-cycle engine 10 to maintain pressure in the crossover passage 22 at a high minimum pressure (typically 20 bar absolute or higher during full load operation) during all four strokes of its pressure/volume cycle. That is, the split-cycle engine 10 is operable to time the XovrC valve 24 and the XovrE valve 26 such that the XovrC and XovrE valves are both open for a substantial period of time (or period of crankshaft rotation) during which the expansion piston 30 descends from its TDC position towards its BDC position and the compression piston 20 simultaneously ascends from its BDC position towards its TDC position. During the period of time (or crankshaft rotation) that the crossover valves 24, 26 are both open, a substantially equal mass of air is transferred (1) from the compression cylinder 12 into the crossover passage 22 and (2) from the crossover passage 22 to the expansion cylinder 14. Accordingly, during this period, the pressure in the crossover passage is prevented from dropping below a predetermined minimum pressure (typically 20, 30, or 40 bar absolute during full load operation). Moreover, during a substantial portion of the engine cycle (typically 80% of the entire engine cycle or greater), the XovrC valve 24 and XovrE valve 26 are both closed to maintain the mass of trapped gas in the crossover passage 22 at a substantially constant level. As a result, the pressure in the crossover passage 22 is maintained at a predetermined minimum pressure during all four strokes of the engine's pressure/volume cycle.

For purposes herein, the method of having the XovrC 24 and XovrE 26 valves open while the expansion piston 30 is descending from TDC and the compression piston 20 is ascending toward TDC in order to simultaneously transfer a substantially equal mass of gas into and out of the crossover passage 22 is referred to herein as the Push-Pull



method of gas transfer. It is the Push-Pull method that enables the pressure in the crossover passage 22 of the split-cycle engine 10 to be maintained at typically 20 bar or higher during all four strokes of the engine's cycle when  
5 the engine is operating at full load.

As discussed earlier, the exhaust valve 34 is disposed in the exhaust port 35 of the cylinder head 33 separate from the crossover passage 22. The structural arrangement of the exhaust valve 34 not being disposed in  
10 the crossover passage 22, and therefore the exhaust port 35 not sharing any common portion with the crossover passage 22, is preferred in order to maintain the trapped mass of gas in the crossover passage 22 during the exhaust stroke. Accordingly, large cyclic drops in pressure are prevented  
15 which may force the pressure in the crossover passage below the predetermined minimum pressure.

XovrE valve 26 opens shortly before the expansion piston 30 reaches its top dead center position. At this time, the pressure ratio of the pressure in crossover  
20 passage 22 to the pressure in expansion cylinder 14 is high, due to the fact that the minimum pressure in the crossover passage is typically 20 bar absolute or higher and the pressure in the expansion cylinder during the exhaust stroke is typically about one to two bar absolute. In other words,  
25 when XovrE valve 26 opens, the pressure in crossover passage 22 is substantially higher than the pressure in expansion cylinder 14 (typically in the order of 20 to 1 or greater). This high pressure ratio causes initial flow of the air and/or fuel charge to flow into expansion cylinder 14 at  
30 high speeds. These high flow speeds can reach the speed of sound, which is referred to as sonic flow. This sonic flow is particularly advantageous to split-cycle engine 10 because it causes a rapid combustion event, which enables

the split-cycle engine 10 to maintain high combustion pressures even though ignition is initiated while the expansion piston 30 is descending from its top dead center position.

5           The split-cycle air-hybrid engine 10 also includes an air reservoir (tank) 40, which is operatively connected to the crossover passage 22 by an air reservoir (tank) valve 42. Embodiments with two or more crossover passages 22 may include a tank valve 42 for each crossover passage 22, which  
10 connect to a common air reservoir 40, or alternatively each crossover passage 22 may operatively connect to separate air reservoirs 40.

          The tank valve 42 is typically disposed in an air reservoir (tank) port 44, which extends from crossover  
15 passage 22 to the air tank 40. The air tank port 44 is divided into a first air reservoir (tank) port section 46 and a second air reservoir (tank) port section 48. The first air tank port section 46 connects the air tank valve 42 to the crossover passage 22, and the second air tank port  
20 section 48 connects the air tank valve 42 to the air tank 40. The volume of the first air tank port section 46 includes the volume of all additional ports and recesses which connect the tank valve 42 to the crossover passage 22 when the tank valve 42 is closed.

25           The tank valve 42 may be any suitable valve device or system. For example, the tank valve 42 may be an active valve which is activated by various valve actuation devices (e.g., pneumatic, hydraulic, cam, electric or the like). Additionally, the tank valve 42 may comprise a tank valve  
30 system with two or more valves actuated with two or more actuation devices.

          Air tank 40 is utilized to store energy in the form of compressed air and to later use that compressed air

to power the crankshaft 16, as described in the  
aforementioned United States Patent No. 7,353,786 to Scuderi  
et al. This mechanical means for storing potential energy  
provides numerous potential advantages over the current  
5 state of the art. For instance, the split-cycle engine 10  
can potentially provide many advantages in fuel efficiency  
gains and NOx emissions reduction at relatively low  
manufacturing and waste disposal costs in relation to other  
technologies on the market, such as diesel engines and  
10 electric-hybrid systems.

By selectively controlling the opening and/or  
closing of the air tank valve 42 and thereby controlling  
communication of the air tank 40 with the crossover passage  
22, the split-cycle air-hybrid engine 10 is operable in an  
15 Engine Firing (EF) mode, an Air Expander (AE) mode, an Air  
Compressor (AC) mode, an Air Expander and Firing (AEF) mode,  
and a Firing and Charging (FC) mode. The EF mode is a non-  
hybrid mode in which the engine operates as described above  
without the use of the air tank 40. The AC and FC modes are  
20 energy storage modes. The AC mode is an air-hybrid  
operating mode in which compressed air is stored in the air  
tank 40 without combustion occurring in the expansion  
cylinder 14 (i.e., no fuel expenditure), such as by  
utilizing the kinetic energy of a vehicle including the  
25 engine 10 during braking. The FC mode is an air-hybrid  
operating mode in which excess compressed air not needed for  
combustion is stored in the air tank 40, such as at less  
than full engine load (e.g., engine idle, vehicle cruising  
at constant speed). The storage of compressed air in the FC  
30 mode has an energy cost (penalty); therefore, it is  
desirable to have a net gain when the compressed air is used  
at a later time. The AE and AEF modes are stored energy  
usage modes. The AE mode is an air-hybrid operating mode in

which compressed air stored in the air tank 40 is used to drive the expansion piston 30 without combustion occurring in the expansion cylinder 14 (i.e., no fuel expenditure). The AEF mode is an air-hybrid operating mode in which  
5 compressed air stored in the air tank 40 is utilized in the expansion cylinder 14 for combustion.

In the AE and AEF modes, the compression cylinder 12 is preferably deactivated to minimize or substantially reduce pumping work (in terms of negative IMEP) performed by  
10 the compression piston 20 on intake air. As will be discussed in further detail herein, the most efficient way to deactivate the compression cylinder 12 is to keep the XovrC valve 24 closed through the entire rotation of the crankshaft 16, and ideally to keep the intake valve 18 open through the  
15 entire rotation of the crankshaft.

In engine embodiments where the intake valve is outwardly opening, the intake valve may be kept open through the entire rotation of crankshaft. However, this exemplary embodiment illustrates the more typical configuration where  
20 the intake valve 18 is inwardly opening. Therefore, in order to avoid compression piston 20 to intake valve 18 contact at the top of the compression piston's stroke, the intake valve 18 must be closed prior to when the ascending piston 20 makes contact with the inwardly opening valve 18.

25 Additionally, it is important to insure that the trapped air is not compressed too much from the angle of intake valve closing to TDC of the compression piston in order to avoid excessive temperature and pressure build-up. Generally, this means that the residual compression ratio at  
30 the point of intake valve 18 closing should be 20 to 1 or less, and more preferably 10 to 1 or less. In exemplary engine 10, the residual compression ratio will be about 20 to 1 at an intake valve 18 closing angle (position) of about 60

CA degrees before TDC of the compression piston 20. When intake valve closing is 60 CA degrees before TDC, it is highly desirable (as discussed in greater detail herein) that intake valve opening be 60 CA degrees after TDC.

5           Accordingly, in order to deactivate the compression cylinder 12 without excessive build-up of air temperature and pressure, it is preferable that the intake valve 18 be kept open through at least 240 CA degrees of the rotation of the crankshaft 16. Moreover, it is more preferable that the  
10 intake valve 18 be kept open through at least 270 CA degrees of the rotation of the crankshaft 16, and it is most preferable that the intake valve be kept open through at least 300 CA degrees of rotation of the crankshaft 16.

          As the intake valve 18 is closed solely in  
15 response to avoiding compression piston 20 to valve 18 contact, air compression (and therefore negative work) will occur as piston 20 ascends toward its top dead center position (TDC). In order to maximize efficiency, a primary aim is therefore to reopen the intake valve 18 at a timing  
20 when the pressure in the compression cylinder 12 is equal to the pressure in the intake port 19 (i.e., when the pressure differential between the compression cylinder 12 and the intake port 19 is substantially zero). In an ideal system, the opening timing of the intake valve 18 would be  
25 symmetrical with the closing timing of the intake valve 18 about top dead center of the compression piston 20. However, in practice, after the intake valve 18 closes during the compression stroke of the compression piston 20, the pressure and temperature in the compression cylinder 12  
30 begins to rise. Some of the heat generated is lost to the cylinder components such as the cylinder walls, the piston crown, and the cylinder head. Therefore, the pressure in the compression cylinder 12 and intake port 19 is equalized

at a slightly earlier timing (relative to top dead center) on the intake stroke of the compression piston 20 than on the compression stroke. In addition, wave effects in the intake port 19 and the flow characteristics of the intake valve 18 (such as the fact that flow is quite restricted at low valve lifts) result in the optimum closing and opening timing of the intake valve 18 deviating slightly from truly symmetrical about top dead center.

Therefore, it is important to keep the closing position (timing) and opening position (timing) of valve 18 substantially (i.e., within plus or minus 10 CA degrees) symmetrical with respect to TDC of piston 20, in order to return as much of the compression work to the crankshaft 16 as possible. For example, if the intake valve 18 is closed at substantially 25 CA degrees before TDC of the compression piston 20 to avoid being hit by the piston 20, then the valve 18 should open at substantially 25 CA degrees after TDC of piston 20. In this way, the compressed air will act as an air spring and return most of the compression work to the crankshaft 16 as the air expands and pushes down on the compression piston 20 when the piston 20 descends away from TDC.

Accordingly, in order to avoid compression piston 20 to valve 18 contact and to reverse as much compression work as possible, it is preferable that the closing and opening positions (timing) of valve 18 are symmetrical, within plus or minus 10 CA degrees, about TDC of compression piston 20 (e.g., if intake valve 18 closes at 25 CA degrees before TDC, then it must open at 25 plus or minus 10 CA degrees after TDC of piston 20). However, it is more preferable if the closing and opening positions of valve 18 are symmetrical, within plus or minus 5 CA degrees, about TDC of piston 20, and most preferable if the closing and

opening positions of valve 18 are symmetrical, within plus or minus 2 CA degrees, about TDC of piston 20.

Also, in the AE and AEF modes, the air tank valve 42 is preferably kept open through the entire rotation of the crankshaft 16 (i.e., the air tank valve 42 is kept open at least during the entire expansion stroke and exhaust stroke of the expansion piston). Compressed air stored in the air tank 40 is released from the air tank 40 into the crossover passage 22 to provide charge air for the expansion cylinder 14. In the AE mode, compressed air from the air tank 40 is admitted to the expansion cylinder 14, at the beginning of an expansion stroke. The air is expanded on the same expansion stroke of the expansion piston 30, transmitting power to the crankshaft 16. The air is then discharged on the exhaust stroke. In the AEF mode, compressed air from the air tank 40 is admitted to the expansion cylinder 14 with fuel at the beginning of an expansion stroke. The air/fuel mixture is ignited, burned and expanded on the same expansion stroke of the expansion piston 30, transmitting power to the crankshaft 16. The combustion products are then discharged on the exhaust stroke.

As shown in FIG. 2 graph labeled: XovrC\_std\_Int\_std, the greatest pumping losses (in terms of negative IMEP) occur in the AE and AEF modes if the XovrC valve and intake valve are operated with standard timing (e.g., the timing used for the EF mode). The pumping losses in this arrangement also increase with engine speed. Therefore, it is apparent that compression cylinder deactivation is necessary to minimize or substantially reduce pumping work performed by the compression piston.

Referring to FIG. 2 graph labeled: XovrC\_open\_Int\_clsd, the pumping losses are reduced if the XovrC valve is kept open and the intake valve is kept

closed. In this arrangement, the compression piston draws in compressed air from the crossover passage during the intake stroke and pushes this air back into the crossover passage during the compression stroke. No ambient intake  
5 air enters the compression cylinder.

Referring to FIG. 2 graph labeled: XovrC\_clsd\_Int\_clsd, the pumping losses are further reduced if both the XovrC valve and the intake valve are kept closed. In this arrangement, the air present in the  
10 compression cylinder is cyclically compressed and decompressed by the compression piston in the form of a large air spring. However, the geometric compression ratios of the compression cylinder 12 and piston 20 are very high (e.g., in excess of 40 to 1). Accordingly, much of the  
15 compression work is lost to an excessive heat of compression.

Referring to FIG. 2 graph labeled: XovrC\_clsd\_Int\_std, the pumping losses are reduced even further if the XovrC valve is kept closed while the intake  
20 valve is operated with standard timing. In this arrangement, the compression cylinder is in fluid communication with the intake port during the intake stroke of the compression piston, and the air present in the compression cylinder is compressed during the compression  
25 piston's compression stroke.

Referring to FIG. 2 graph labeled: XovrC\_clsd\_Int\_open, as discussed earlier, the pumping losses are the lowest if the XovrC valve is kept closed and the intake valve is kept open. In this arrangement, the  
30 compression piston draws in intake air from the intake port during its intake stroke and pushes the air back into the intake port during its compression stroke. A minimum amount of compression work is done since the intake valve 18 is



2011227531 21 Aug 2012

- 22 -

closed only in response to avoiding contact with compression  
piston 20. Additionally, most of that compression work is  
reversible when the opening and closing timings of intake valve 18  
are substantially symmetrical relative to TDC of the compression  
5 piston 20.

Although the invention has been described by reference  
to a specific embodiment, it should be understood that numerous  
changes may be made within the spirit and scope of the inventive  
concepts described. Accordingly, it is intended that the  
10 invention not be limited to the described embodiment, but that it  
have the full scope defined by the language of the following  
claims.

The reference in this specification to any prior  
publication (or information derived from it), or to any matter  
15 which is known, is not, and should not be taken as, an  
acknowledgement or admission or any form of suggestion that that  
prior publication (or information derived from it) or known matter  
forms part of the common general knowledge in the field of  
endeavour to which this specification relates.

20 Throughout this specification and the claims which  
follow, unless the context requires otherwise, the word  
"comprise", and variations such as "comprises" or "comprising",  
will be understood to imply the inclusion of a stated integer or  
step or group of integers or steps but not the exclusion of any  
25 other integer or step or group of integers or steps.

**CLAIMS**

What is claimed is:

1. A split-cycle air-hybrid engine comprising:
  - 5 a crankshaft rotatable about a crankshaft axis;
  - a compression piston slidably received within a compression cylinder and operatively connected to the crankshaft such that the compression piston reciprocates through an intake stroke and a compression stroke during a  
10 single rotation of the crankshaft;
  - an intake valve selectively controlling air flow into the compression cylinder;
  - an expansion piston slidably received within an expansion cylinder and operatively connected to the  
15 crankshaft such that the expansion piston reciprocates through an expansion stroke and an exhaust stroke during a single rotation of the crankshaft;
  - a crossover passage interconnecting the compression and expansion cylinders, the crossover passage including a crossover compression (XovrC) valve and a  
20 crossover expansion (XovrE) valve defining a pressure chamber therebetween;
  - an air reservoir operatively connected to the crossover passage and selectively operable to store  
25 compressed air from the compression cylinder and to deliver compressed air to the expansion cylinder; and
  - an air reservoir valve selectively controlling air flow into and out of the air reservoir;
  - the engine being operable in an Air Expander (AE)  
30 mode and an Air Expander and Firing (AEF) mode, wherein, in the AE and AEF modes, the XovrC valve is kept closed during an entire rotation of the crankshaft, and the intake valve

is kept open for at least 240 CA degrees of the same rotation of the crankshaft.

2. The split-cycle air-hybrid engine of claim 1, wherein, in the AE and AEF modes, the intake valve is kept  
5 open for at least 270 CA degrees of the same rotation of the crankshaft.

3. The split-cycle air-hybrid engine of claim 1, wherein, in the AE and AEF modes, the intake valve is kept  
10 open for at least 300 CA degrees of the same rotation of the crankshaft.

4. The split-cycle air-hybrid engine of claim 1, wherein, in the AE and AEF modes, a residual compression ratio at an intake valve closing position is 20 to 1 or less.

15 5. The split-cycle air-hybrid engine of claim 1, wherein, in the AE and AEF modes, a residual compression ratio at an intake valve closing position is 10 to 1 or less.

6. The split-cycle air-hybrid engine of claim 1,  
20 wherein, in the AE and AEF modes, the intake valve closing position and intake valve opening position are symmetrical, within plus or minus 10 CA degrees, about the top dead center position of the compression piston.

7. The split-cycle air-hybrid engine of claim 1,  
25 wherein, in the AE and AEF modes, the intake valve closing position and intake valve opening position are symmetrical, within plus or minus 5 CA degrees, about the top dead center position of the compression piston.

8. The split-cycle air-hybrid engine of claim 1,  
30 wherein, in the AE and AEF modes, the intake valve closing position and intake valve opening position are symmetrical, within plus or minus 2 CA degrees, about the top dead center position of the compression piston.

9. The split-cycle air-hybrid engine of claim 1, wherein, in the AE and AEF modes, the intake valve is kept open during the entire same rotation of the crankshaft.

10. The split-cycle air-hybrid engine of claim 1, wherein, in the AE mode, the air reservoir valve is open, and compressed air from the air reservoir is admitted to the expansion cylinder, at the beginning of an expansion stroke, the air is expanded on the same expansion stroke of the expansion piston, transmitting power to the crankshaft, and the air is discharged on the exhaust stroke.

11. The split-cycle air-hybrid engine of claim 1, wherein, in the AEF mode, the air reservoir valve is open, and compressed air from the air reservoir is admitted to the expansion cylinder with fuel, at the beginning of an expansion stroke, which is ignited, burned and expanded on the same expansion stroke of the expansion piston, transmitting power to the crankshaft, and the combustion products are discharged on the exhaust stroke.

12. A split-cycle air-hybrid engine comprising:  
a crankshaft rotatable about a crankshaft axis;  
a compression piston slidably received within a compression cylinder and operatively connected to the crankshaft such that the compression piston reciprocates through an intake stroke and a compression stroke during a single rotation of the crankshaft;

an intake valve selectively controlling air flow from an intake port into the compression cylinder;

an expansion piston slidably received within an expansion cylinder and operatively connected to the crankshaft such that the expansion piston reciprocates through an expansion stroke and an exhaust stroke during a single rotation of the crankshaft;

a crossover passage interconnecting the compression and expansion cylinders, the crossover passage including a crossover compression (XovrC) valve and a crossover expansion (XovrE) valve defining a pressure chamber therebetween;

5 an air reservoir operatively connected to the crossover passage and selectively operable to store compressed air from the compression cylinder and to deliver compressed air to the expansion cylinder; and

10 an air reservoir valve selectively controlling air flow into and out of the air reservoir;

the engine being operable in an Air Expander (AE) mode and an Air Expander and Firing (AEF) mode, wherein, in the AE and AEF modes, the XovrC valve is kept closed during an entire rotation of the crankshaft, and the intake valve is opened at a position at which pressure in the compression cylinder is approximately equal to pressure in the intake port.

13. A method of operating a split-cycle air-hybrid engine including:

20 a crankshaft rotatable about a crankshaft axis;  
a compression piston slidably received within a compression cylinder and operatively connected to the crankshaft such that the compression piston reciprocates through an intake stroke and a compression stroke during a single rotation of the crankshaft;

an intake valve selectively controlling air flow into the compression cylinder;

30 an expansion piston slidably received within an expansion cylinder and operatively connected to the crankshaft such that the expansion piston reciprocates through an expansion stroke and an exhaust stroke during a single rotation of the crankshaft;

a crossover passage interconnecting the compression and expansion cylinders, the crossover passage including a crossover compression (XovrC) valve and a crossover expansion (XovrE) valve defining a pressure chamber therebetween;

5 an air reservoir operatively connected to the crossover passage and selectively operable to store compressed air from the compression cylinder and to deliver compressed air to the expansion cylinder; and

10 an air reservoir valve selectively controlling air flow into and out of the air reservoir;

the engine being operable in an Air Expander (AE) mode and an Air Expander and Firing (AEF) mode;

the method including the steps of:

15 keeping the XovrC valve closed during an entire rotation of the crankshaft; and

keeping the intake valve open during at least 240 CA degrees of the same rotation of the crankshaft;

20 whereby the compression cylinder is deactivated to reduce pumping work performed by the compression piston on intake air.

14. The method of claim 13, including the step of keeping the intake valve closing position and the intake valve opening position symmetrical, within plus or minus 5 CA degrees, about the top dead center position of the compression piston.

15. The method of claim 13, including the step of keeping the intake valve open during the entire same rotation of the crankshaft.

30 16. The method of claim 13, including the step of closing the intake valve such that a residual compression ratio at the intake valve closing position is 20 to 1 or less.

17. The method of claim 13, further including the steps of:

opening the air reservoir valve; and

operating the engine in the AE mode by admitting  
5 compressed air from the air reservoir to the expansion  
cylinder, at the beginning of an expansion stroke, expanding  
the air on the same expansion stroke of the expansion  
piston, transmitting power to the crankshaft, and  
discharging the air on the exhaust stroke.

10 18. The method of claim 13, further including the steps of:

opening the air reservoir valve; and

operating the engine in the AEF mode by admitting  
compressed air from the air reservoir to the expansion  
15 cylinder with fuel, at the beginning of an expansion stroke,  
which is ignited, burned and expanded on the same expansion  
stroke of the expansion piston, transmitting power to the  
crankshaft, and discharging the combustion products on the  
exhaust stroke.





Fig. 2

